

AREA DRAIN / PARKING DRAIN WITH 12" SQUARE TOP HEAVY DUTY
MODEL NO: **R3312**

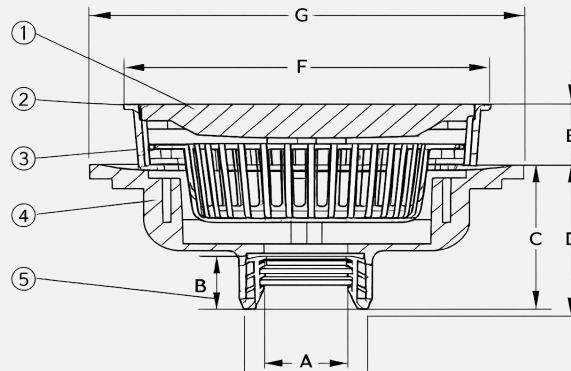

- ✓ **PRODUCT DESCRIPTION:** Epoxy Coated Cast Iron Body Area Drain/Parking drain with 12" (305mm) Heavy Duty Cast Iron Square top grating. Cast Iron Frame for Grating, Seepage pan and Combination membrane flashing clamp, with suspended polypropylene sediment bucket.

✓ **CRITICAL TO QUALITY (CTQ) DIMENSION :**

DIMENSION	DESCRIPTION	DIMENSION IN INCHES {mm}	
		3	4
A	PIPE SIZE	3 (73)	4 (103)
B	GASKET HEIGHT	1-15/16 (50)	1-3/4 (45)
C	C.I BODY HEIGHT	5-1/4 (133)	5-1/4 (133)
D	C.I BODY HEIGHT WITH GASKET	5-9/16 (141)	5-9/16 (141)
E	FRAME HEIGHT	2-1/2 (64)	2-1/2 (64)
F	SQUARE FRAME TOP SIZE	12-1/2 (318)	12-1/2 (318)
G	C.I BODY OUTER DIAMETER	15 (381)	15 (381)
GRATE OPEN AREA Sq. In. (cm ²)		42 (271)	
OUTLET TYPE		INSIDE GASKET	

✓ **LIST OF COMPONENTS :**

COMPONENT	DESCRIPTION
1	SQUARE HEAVY DUTY D.I GRATE
2	SQUARE HEAVY DUTY D.I FRAME
3	SUSPENDED POLYPROPYLENE SEDIMENT BUCKET
4	CAST IRON BODY
5	NEO LOC GASKET
6	GI HT FLANGE HEX HEAD BOLT 10MM X 32MM